

## AN INTEGRAL EQUATION FOR THE PROBLEM OF SMOOTH INDENTATION OF ORTHOTROPIC BEAMS

BHAVANI V. SANKAR

Department of Aerospace Engineering, Mechanics, and Engineering Science,  
 University of Florida, Gainesville, FL 32611, U.S.A.

(Received 30 April 1988; in revised form 23 August 1988)

**Abstract**—An integral equation for the problem of smooth contact between a rigid indenter and an orthotropic beam is formulated using an approximate Green's function for surface displacements in the beam, which is obtained as the sum of half-plane solutions for surface displacements, and beam theory deflections. The left and right Green's functions for beam slope are approximated as a single function with continuous derivatives using a least squares error procedure. A closed form solution is obtained for the integral equation. Solutions are obtained for two cases: symmetric indentation of simply supported orthotropic beams and indentation of cantilever beams. Closed form expressions are derived for contact stresses and the contact force-contact length relation in terms of a nondimensional beam parameter  $B$  and a nondimensional contact parameter  $\beta$ .

### NOTATION

$B$	nondimensional beam parameter = $\frac{\pi D_2 l^3}{32 D_1 h^3}$
$b$	beam width
$2c$	contact length
$\bar{c}$	$c/l$
$D_1, D_2$	stiffness coefficients (functions of elastic constants)
$E_1, E_2$	Young's modulus in 1 and 2 directions
$g(x, \xi)$	Green's function
$g'_b$	Green's function for beam slope
$g'_h$	Green's function for half-plane boundary slope
$G_{1,2}$	shear modulus
$h$	beam thickness
$l$	beam length
$P$	contact force
$\hat{P}$	nondimensional contact force = $(4PT)/(\pi D_2 b l^2)$
$p$	contact stresses
$\bar{p}$	nondimensional contact stress = $(pR)/(D_2 l)$
$\hat{p}$	nondimensional contact stress = $(\pi b c p)/(2P)$
$q_n$	coefficients in the Chebyshev polynomial for $\bar{p}$
$R$	indenter radius of curvature
$T_n$	Chebyshev polynomials of first kind
$U_n$	Chebyshev polynomials of second kind
$x, y$	coordinate axes
$\bar{x}$	$(x - x_c)/c$
$x_i$	$x$ -coordinate of indenter center
$x_c$	$x$ -coordinate of contact center
$\bar{x}_i$	$x_i/l$
$\bar{x}_c$	$x_c/l$
$\beta$	nondimensional contact parameter = $8.75 B \bar{c}^4$
$\Delta$	indenter $y$ -displacement
$\theta_{h0}$	boundary slope of half-plane at $x = 0$
$\nu_{1,2}$	Poisson's ratio
$\xi$	dummy variable
$\bar{\xi}$	$(\xi - x_c)/c$

### 1. INTRODUCTION

The problem of smooth indentation of beams of finite length by a rigid cylindrical indenter has been studied by several authors. Keer and Ballarini (1983), Keer and Miller (1983) and Keer and Schonberg (1986) approached the problem via a local-global technique. Their methods of analysis superpose an infinite-layer solution, derived through the use of integral transforms, on a pure-bending beam-theory solution. An integral equation is obtained for

the contact problem, which is solved numerically. Sankar and Sun (1983) obtained a solution for displacements in a beam by superposing beam theory deflections and displacements obtained by solving the plane elasticity equations using finite Fourier transforms. A point matching technique was used to modify the integral equation as a system of linear algebraic equations. Later, Sun and Sankar (1985) extended the method for the problem of indentation of initially stressed orthotropic beams.

Sankar (1987a) derived an approximate Green's function for surface displacements in a beam by superposing the elasticity solution for half-plane and beam theory deflections. The Green's function approach simplified the formulation of the contact problem by eliminating the need for solving the elasticity equations, because half-plane displacements can be obtained in a closed form. The contact problem was solved by a least squares collocation procedure. Application of this method for orthotropic beams can be found in Sankar (1987b).

In all studies referred to above, solution of the integral equation for the contact problem was obtained numerically, and hence the effect of beam dimensions, indenter radius of curvature and degree of orthotropy on the contact behavior could be understood only by means of numerical examples. In this paper, an approximate solution for the problem of smooth contact between a rigid indenter and an orthotropic beam is obtained by following the Green's function approach. The left and right Green's functions for beam slope are approximated by a single function which has a continuous second derivative, unlike the actual Green's function. The integral equation for the contact problem is then solved exactly. Closed-form solutions are obtained for contact stresses and contact force-contact length relation. As a result of this method, suitable nondimensional parameters are identified, and the contact behavior of an orthotropic beam is described with few parameters.

Although the present method can be applied to any type of beam support, two examples are chosen for illustration. In the first example, symmetric indentation of a simply supported orthotropic beam is considered. In this case the center of contact length always coincides with the beam center, and the contact stresses are symmetric about the center. In the second example, a cantilever beam is indented by a smooth indenter, in which case the center of contact region relative to the indenter depends on the contact force. Thus an additional unknown is introduced.

It may be noted that the approximate Green's function is valid only if the load is not very close to either end of the beam (Sankar, 1987a). In the present study we will assume that the contact region is not within  $0.25l$  of the beam ends.

## 2. SYMMETRIC INDENTATION OF A SIMPLY SUPPORTED BEAM

The problem is depicted in Fig. 1. The orthotropic beam is of rectangular cross section  $b \times h$  and length  $l$ . The principal material directions 1 and 2 are parallel to the  $x$  and  $y$  axes respectively.

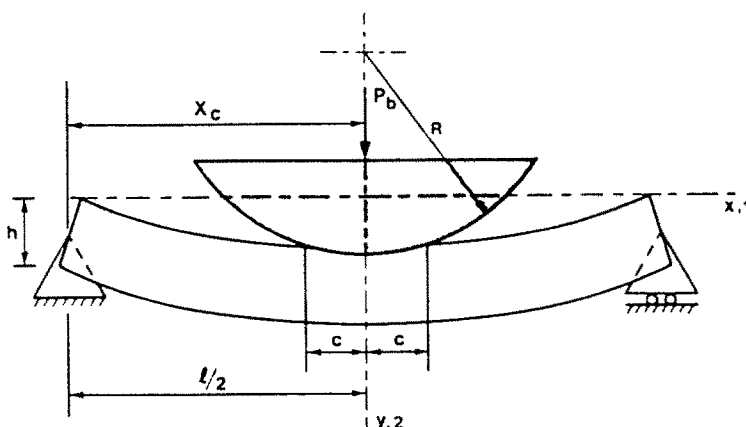

Fig. 1. Symmetric indentation of an orthotropic beam.

The integral equation for the symmetric contact problem is

$$b \int_{-c}^{+c} p(\xi) g(x, \xi) d\xi = \Delta - \frac{x^2}{2R}, \quad (1)$$

where  $p(x) = -\sigma_{xy}(x, 0)$  is the unknown contact stress beneath the indenter,  $2c$  is the contact length,  $g(x, \xi)$  is the Green's function for surface displacements in a beam,  $R$  is the indenter radius of curvature and  $\Delta$  is the  $y$ -displacement of the indenter. It should be noted that eqn (1) assumes that the indenter has a parabolic profile. If the indenter is circular, eqn (1) is valid only for  $c/R \ll 1$ . The unknown displacement  $\Delta$  can be eliminated by differentiating eqn (1) with respect to  $x$ . Thus the integral equation takes the form

$$b \int_{-c}^{+c} p(\xi) g'(x, \xi) d\xi = -x/R, \quad (2)$$

where a prime denotes differentiation with respect to  $x$ . It was shown in Sankar (1987b) that an approximate  $g(x, \xi)$  can be obtained by adding  $g_h(x, \xi)$ , the Green's function for surface displacements in an orthotropic half-plane, and  $g_b(x, \xi)$ , the Green's function for beam deflections. Thus eqn (2) can be written as

$$b \int_{-c}^{+c} p(\xi) [g'_h(x, \xi) + g'_b(x, \xi)] d\xi = -x/R, \quad (3)$$

where  $g'_h$  is given by (Sankar, 1987b):

$$g'_h(x, \xi) = \frac{2}{\pi b D_2 (\xi - x)}. \quad (4)$$

For the case of plane stress parallel to the  $x$ - $y$  plane,  $D_2 = 2E_2/(\lambda_1 + \lambda_2)$ , where  $\lambda_1$  and  $\lambda_2$  are the roots of the characteristic equation  $S_{11}\lambda^4 - (2S_{12} + S_{66})\lambda^2 + S_{22} = 0$ ,  $S_{11} = 1/E_1$ ,  $S_{22} = 1/E_2$ ,  $S_{66} = 1/G_{12}$ ,  $S_{12} = -\nu_{12}/E_1$ ,  $E_1$  and  $E_2$  are the Young's moduli in the 1 and 2 directions,  $G_{12}$  is the shear modulus in the 1-2 plane and  $\nu_{12}$  is the Poisson's ratio. For the case of plane strain,  $D_2$  will be slightly different (Lekhnitskii, 1981).

The beam Green's function for the slope is

$$g'_b(x, \xi) = (l^2/D_1 b h^3) [2(\xi/l)^3 + 6(\xi/l)(x/l)^2 - 3(x/l) + (\xi/l) + 3\phi(x, \xi)], \quad (5)$$

where  $D_1 = E_1$  for plane stress and  $D_1 = E_1/(1 - \nu_{12}^2)$  for plane strain. The function  $\phi(x, \xi)$  is defined as

$$\phi(x, \xi) = -\left(\frac{x - \xi}{l}\right)^2, \quad x < \xi,$$

and

$$\phi(x, \xi) = +\left(\frac{x - \xi}{l}\right)^2, \quad x > \xi. \quad (6)$$

It may be noted that  $\phi$  is an odd function of the argument  $(x - \xi)$ , and can be expanded in terms of odd powers of  $(x - \xi)$ . We shall approximate  $\phi$  by a single function of the type  $c_1(x - \xi) + c_2(x - \xi)^3$ . The constants  $c_1$  and  $c_2$  depend upon the degree of accuracy and the range of  $(x - \xi)$  over which the approximation is sought. In the present study, the maximum contact length is assumed to be given by  $2c = 0.5l$ . We will therefore approximate  $\phi(x, \xi)$  such that the error is a minimum over the range  $-0.5 < (x - \xi)/l < +0.5$ . Using the least

squares error approximation procedure, the constants  $c_1$  and  $c_2$  are found to be  $5/32$  and  $35/24$  respectively. Thus  $\phi(x, \xi)$  can be written as

$$\phi(x, \xi) = \frac{5}{32} \left( \frac{x-\xi}{l} \right) + \frac{35}{24} \left( \frac{x-\xi}{l} \right)^3. \tag{7}$$

From eqns (5) and (7), we obtain

$$g'_b(x, \xi) = (l^2/32D_1bh^3)f(\bar{x}, \bar{\xi}), \tag{8}$$

where

$$f(\bar{x}, \bar{\xi}) = (-81\bar{x}\bar{c} + 140\bar{x}^3\bar{c}^3) + 420\bar{x}\bar{c}^3\bar{\xi}^2 + (17\bar{c} - 228\bar{x}^2\bar{c}^3)\bar{\xi} - 76\bar{c}^3\bar{\xi}^3, \tag{9}$$

$\bar{x} = x/c$ ,  $\bar{\xi} = \xi/c$ , and  $\bar{c} = c/l$ . The expressions for  $g'_b$  given by eqns (5) and (8) are compared in Fig. 2 for two extreme cases,  $\xi/l = 0$  and  $0.25$ . The agreement is quite good.

The function  $f(\bar{x}, \bar{\xi})$  can be rewritten as

$$f(\bar{x}, \bar{\xi}) = (-81\bar{x}\bar{c} + 140\bar{x}^3\bar{c}^3 + 210\bar{x}\bar{c}^3)T_0(\bar{\xi}) + (17\bar{c} - 228\bar{c}^3\bar{x}^2 - 57\bar{c}^3)T_1(\bar{\xi}) + 210\bar{c}^3\bar{x}T_2(\bar{\xi}) - 19\bar{c}^3T_3(\bar{\xi}), \tag{10}$$

where  $T_n$  are Chebyshev polynomials of the first kind, given by  $T_0(s) = 1$ ,  $T_1(s) = s$ ,  $T_2(s) = 2s^2 - 1$ ,  $T_3(s) = 4s^3 - 3s$  and  $T_4(s) = 8s^4 - 8s^2 + 1$ .

We will introduce a nondimensional parameter  $B = (\pi/32)(D_2/D_1)(l/h)^3$  and a nondimensional contact pressure  $\bar{p} = (pR)/(D_2l)$ . From eqns (4), (8) and (10), the integral equation (3) takes the form

$$\int_{-1}^{+1} \left[ \frac{2}{\pi(\bar{\xi} - \bar{x})} + \frac{B\bar{c}}{\pi} f(\bar{x}, \bar{\xi}) \right] \bar{p}(\bar{\xi}) d\bar{\xi} = -\bar{c}\bar{x}. \tag{11}$$

The contact pressure  $\bar{p}(\bar{x})$  can be assumed to be of the form

$$\bar{p}(\bar{x}) = (1 - \bar{x}^2)^{-1/2} \sum_{n=0}^4 q_n T_n(\bar{x}). \tag{12}$$

In order to evaluate the first term of the integral in eqn (11) we will use the result (Gladwell, 1980)

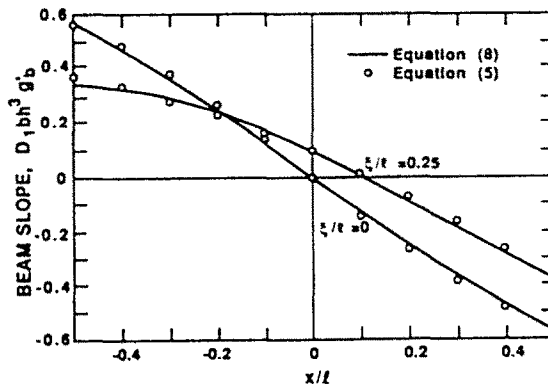

Fig. 2. Exact and approximate slopes of simply supported beams.

$$\{P\} \frac{1}{\pi} \int_{-1}^{+1} \frac{(1-t^2)^{-1/2} T_n(t)}{(t-s)} dt = U_{n-1}(s), \quad n = 0, 1, 2, \dots, \text{ and } |s| < 1,$$

where  $\{P\}$  denotes the Cauchy principal value and  $U_n(s)$  are the Chebyshev polynomials of the second kind defined by  $U_{-1}(s) = 0$ ,  $U_0(s) = 1$ ,  $U_1(s) = 2s$ ,  $U_2(s) = 4s^2 - 1$ ,  $U_3(s) = 8s^3 - 4s$  and  $U_4(s) = 16s^4 - 12s^2 + 1$ . The second term of the integral in eqn (11) can be easily evaluated using the orthogonality condition

$$\int_{-1}^{+1} (1-t^2)^{-1/2} T_m(t) T_n(t) dt = \begin{cases} 0, & n \neq m \\ \pi/2, & n = m \neq 0 \\ \pi, & n = m = 0. \end{cases}$$

Thus eqn (11) takes the form

$$2q_1 + 4q_2\bar{x} + q_3(8\bar{x}^2 - 2) + q_4(16\bar{x}^3 - 8\bar{x}) + B\{q_0(-81\bar{c}^2\bar{x} + 140\bar{c}^4\bar{x}^3 + 210\bar{c}^4\bar{x}) + q_1(8.5\bar{c}^2 - 114\bar{c}^4\bar{x}^2 - 28.5\bar{c}^4) + q_2(105\bar{c}^4\bar{x}) + q_3(-9.5\bar{c}^4)\} = -\bar{c}\bar{x}. \quad (13)$$

By equating the coefficients of  $\bar{x}^0, \dots, \bar{x}^3$  on both sides of eqn (13), we obtain four equations (14)–(17) in the unknowns  $q_0, \dots, q_4$ .

$$\{2 + B(8.5\bar{c}^2 - 28.5\bar{c}^4)\}q_1 + (-9.5B\bar{c}^4 - 2)q_3 = 0 \quad (14)$$

$$B(210\bar{c}^4 - 81\bar{c}^2)q_0 + (4 + 105B\bar{c}^4)q_2 - 8q_4 = -\bar{c} \quad (15)$$

$$(-114B\bar{c}^4)q_1 + 8q_3 = 0 \quad (16)$$

$$104B\bar{c}^4q_0 + 16q_4 = 0. \quad (17)$$

The fifth equation (18) is obtained from the fact that the contact stresses vanish at the ends of contact zone, i.e.

$$q_0 + q_1 + q_2 + q_3 + q_4 = 0. \quad (18)$$

The solution of eqns (14)–(18) is as follows:

$$q_0 = \bar{c}/(4 + 81B\bar{c}^2 - 210B\bar{c}^4 - 918.75B^2\bar{c}^8), \quad (19)$$

$$q_1 = q_3 = 0, \quad (20)$$

$$q_2 = (\beta - 1)q_0, \quad (21)$$

and

$$q_4 = -\beta q_0, \quad (22)$$

where  $\beta$  is a nondimensional parameter defined as  $\beta = 8.75B\bar{c}^4$ .

#### Contact stresses

The contact force is given by

$$P = b \int_{-c}^{+c} p(x) dx,$$

and, using eqn (12), we obtain

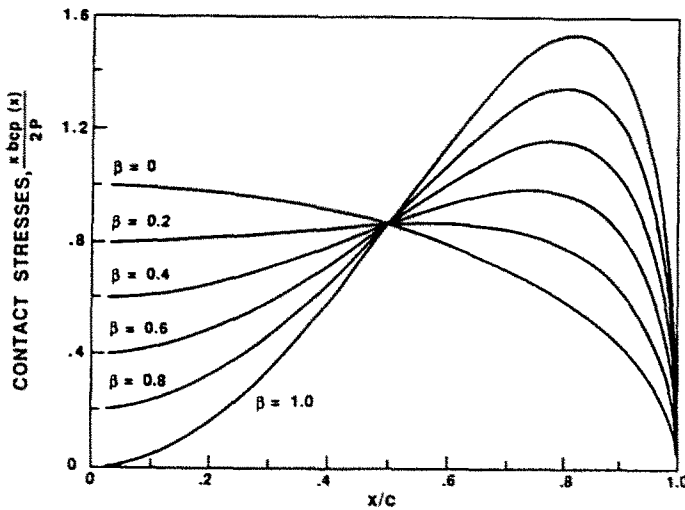

Fig. 3. Contact stresses in simply supported beams.

$$P = (\pi b D_2 l c / R) q_0. \quad (23)$$

We shall plot the contact stresses using another nondimensional contact stress parameter,  $\hat{p} = (\pi b c / 2P) p(x)$ . Using eqns (12) and (23) and substituting for  $q_2$  and  $q_4$  in terms of  $q_0$  from eqns (21) and (22), we obtain

$$\hat{p} = \sqrt{1 - \bar{x}^2 [1 - \beta(1 - 4\bar{x}^2)]}. \quad (24)$$

Expression (24) defines the contact stress distribution in a simply supported orthotropic beam in terms of a single nondimensional parameter  $\beta$ , and it is plotted in Fig. 3 for  $0 < \beta < 1$ . The curve for  $\beta = 0$  represents the half-plane solution. It should be mentioned that the above solution assumes that no separation occurs between the indenter and the beam. In fact, separation occurs at  $\beta = 1$ . It is interesting to see that the value of  $\hat{p}$  at  $\bar{x} = 0.5$  is a constant,  $\sqrt{3}/2$ , for all beams. This can be observed in all the previous numerical results, for example Keer and Ballarini (1983), Keer and Miller (1983), Keer and Schonberg (1986), Sankar and Sun (1983) and Sankar (1987a, b), until the indenter separates from the beam.

#### Contact force-contact length relation

We define a nondimensional contact force  $\hat{P} = (4PR)/(\pi D_2 b l^2)$ . From eqns (19) and (23) the load-contact length relation takes the form

$$\hat{P} = \bar{c}^2 / (1 + 20.25 B \bar{c}^2 - 52.5 B \bar{c}^4 - 229.6875 B^2 \bar{c}^6). \quad (25)$$

For a half plane, the above relation takes the simple form  $\hat{P} = \bar{c}^2$ . The variation of  $\hat{P}$  with  $\bar{c}$  is plotted in Fig. 4 for various values of the beam parameter  $B$ . The curve for  $B = 0$  corresponds to the half-plane solution. The effect of  $B$  is to increase the contact length for a given contact force. In Sankar (1987b) the effect of beam curvature was taken into account by considering the problem as that of contact between two curved bodies. Such an assumption will result in a  $\hat{P}$ - $\bar{c}$  relation of the form

$$\hat{P} = \bar{c}^2 / (1 + 24 B \bar{c}^2), \quad (26)$$

which is a reasonable approximation of eqn (25) for small  $\bar{c}$ .

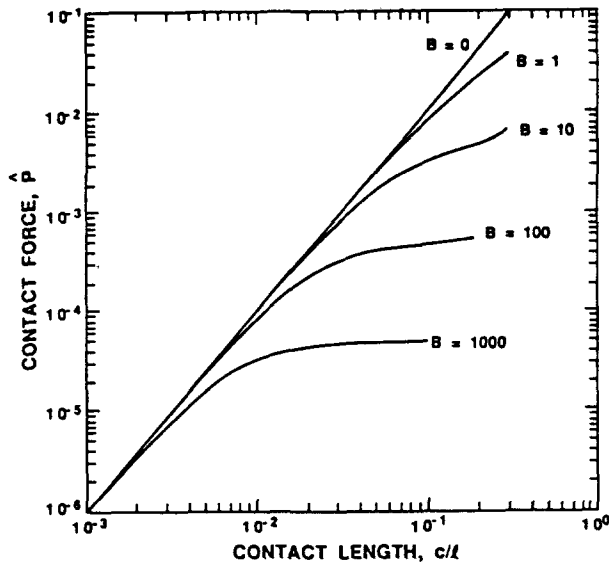

Fig. 4. Contact force-contact length relation in simply supported beams.

3. INDENTATION OF AN ORTHOTROPIC CANTILEVER BEAM

In this section we consider the case of a cantilever beam, as shown in Fig. 5. The indenter location is given by  $x_i$ . Initial contact will be a line contact at  $x = x_i$ . As the load is applied,  $c$  will increase, and the center of contact defined by  $x_c$  will move towards the fixed end of the beam. Thus an additional unknown  $x_c$  is introduced. However, the contact stresses will be unsymmetric about the center of contact length, and so we have one more equation which states that the contact stresses vanish at the left end of the contact region too.

There is another important difference between symmetric and nonsymmetric cases. The solution for  $y$ -displacements in the half-plane contains arbitrary terms for translation and rotation, which means that the expression for the boundary slope of the half-plane will contain an arbitrary constant. In the case of symmetric contact, the rotation term can be assumed to be zero. In the case of the cantilever beam problem, this difficulty can be overcome by subtracting  $g'_h(0, \xi)$  from  $g'_h(x, \xi)$  in the integral equation (3). This means that we are measuring the boundary slope relative to the slope at  $x = 0$ . Thus eqn (3) will become

$$b \int_{x_c - c}^{x_c + c} p(\xi) [g'_h(x, \xi) - g'_h(0, \xi) + g'_b(x, \xi)] d\xi = -(x - x_i)/R. \tag{27}$$

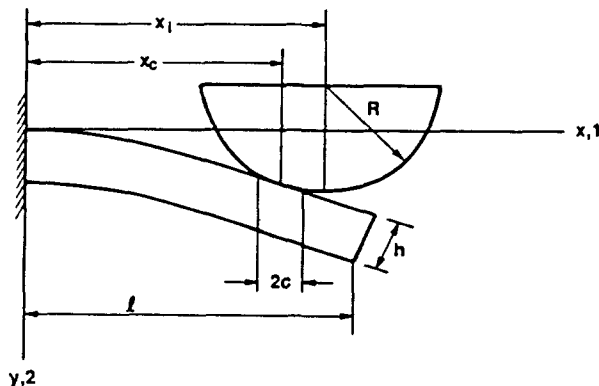

Fig. 5. Indentation of an orthotropic cantilever beam.

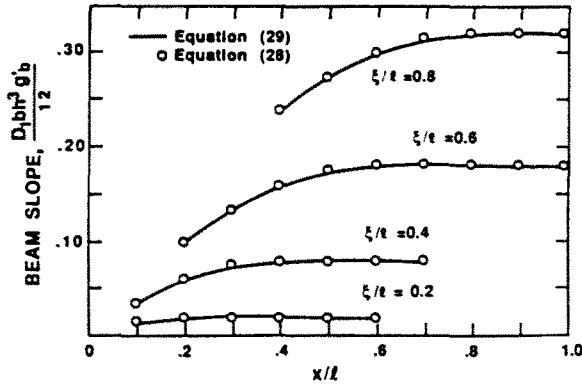

Fig. 6. Exact and approximate slopes of cantilever beams.

The second term in the above integral is the boundary slope of the half-plane at  $x = 0$  due to the applied load  $P$ , which we shall denote by  $\theta_{h_0}$ , i.e.

$$b \int_{-c}^{+c} g'_h(0, \xi) p(\xi) d\xi = \theta_{h_0}.$$

Although eqn (27) can be solved using the procedure described in section 2, we will simplify the derivations by approximating  $\theta_{h_0}$  as the slope due to a concentrated force  $P$  at  $x = x_c$ . From eqn (4),  $\theta_{h_0} = (2P/\pi b D_2)(1/x_c)$ . Substituting for  $P$  from eqn (23), we obtain  $\theta_{h_0} = (2lc/Rx_c)q_0$ .

For a cantilever beam, the slope is given by

$$g'_b(x, \xi) = (12l^2/D_1 b h^3) \left\{ \frac{\xi^2}{2l^2} - \left( \frac{x-\xi}{2l} \right)^2 \right\} + \frac{1}{4} \phi(x, \xi), \tag{28}$$

where  $\phi(x, \xi)$  is defined in eqn (6). As before, we will approximate the Green's function by a single function as

$$g'_b(x, \xi) = (l^2/32D_1 b h^3) f(\bar{x}, \bar{\xi}), \tag{29}$$

where

$$f(\bar{x}, \bar{\xi}) = 384 \left\{ \frac{1}{2} (\bar{c}\bar{\xi} + \bar{x}_c)^2 - \frac{1}{4} \bar{c}^2 (\bar{x} - \bar{\xi})^2 + \frac{1}{128} \bar{c} (\bar{x} - \bar{\xi}) + \frac{3}{64} \bar{c}^3 (\bar{x} - \bar{\xi})^3 \right\},$$

$$\bar{x} = (x - x_c)/c, \quad \bar{\xi} = (\xi - x_c)/c, \quad \bar{x}_i = x_i/l, \quad \text{and} \quad \bar{x}_c = x_c/l.$$

Comparison of the exact (eqn (28)) and approximate (eqn (29)) beam slopes is shown in Fig. 6 for various values of  $\xi$ .

The contact stresses are assumed to be of the form given by eqn (12). The integral equation (27) takes the form

$$\int_{-1}^{+1} \left[ \frac{2}{\pi(\bar{\xi} - \bar{x})} + \frac{B}{\pi} \bar{c} f(\bar{x}, \bar{\xi}) \right] \bar{p}(\bar{\xi}) d\bar{\xi} - (2\bar{c}/\bar{x}_c) q_0 = \bar{x}_i - \bar{x}_c - \bar{c}\bar{x}. \tag{30}$$

The solution procedure is similar to that explained in section 2 and so is not repeated here. By equating the coefficients of  $\bar{x}^0, \dots, \bar{x}^3$  on both sides of eqn (30), we obtain four equations (31)–(34) in the unknown  $q_s$ . The remaining two equations (35) and (36) are obtained from the fact that  $p = 0$  at  $\bar{x} = -1$  and  $\bar{x} = +1$ .

$$[B\bar{c}(192\bar{x}_c^2 + 48\bar{c}^2) - (2\bar{c}/\bar{x}_c)] q_0 + [2 + B\bar{c}^2(192\bar{x}_c - 7.5 - 52.5\bar{c}^2)] q_1 + 24B\bar{c}^3 q_2 + (-2 - 17.5B\bar{c}^4) q_3 = \bar{x}_i - \bar{x}_c \tag{31}$$



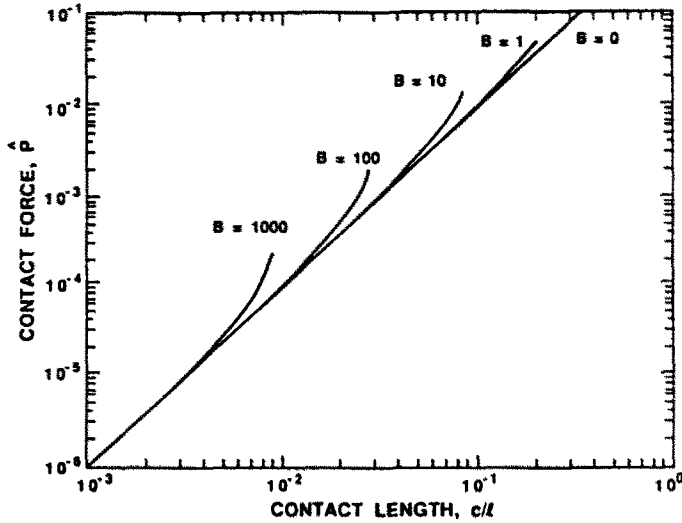

Fig. 7. Contact force–contact length relation in cantilever beams.

$$B\bar{c}^2(15 + 210\bar{c}^2)q_0 + 96B\bar{c}^3q_1 + (4 + 105B\bar{c}^4)q_2 - 8q_3 = -\bar{c} \tag{32}$$

$$-96B\bar{c}^3q_0 - 210B\bar{c}^4q_1 + 8q_3 = 0 \tag{33}$$

$$140B\bar{c}^4q_0 + 16q_4 = 0 \tag{34}$$

$$q_0 + q_1 + q_2 + q_3 + q_4 = 0 \tag{35}$$

$$q_0 - q_1 + q_2 - q_3 + q_4 = 0. \tag{36}$$

Equations (33)–(36) can be used to solve for  $q_1, \dots, q_4$  in terms of  $q_0$ . The results are:  $q_1 = (-12B\bar{c}^3)q_0/(1 + 3\beta)$ ,  $q_2 = (-1 + \beta)q_0$ ,  $q_3 = -q_1$ , and  $q_4 = -\beta q_0$ .

*Contact force–contact length relation*

Substituting for  $q_1, \dots, q_4$  in terms of  $q_0$  in eqn (32), one can obtain a relation between  $q_0$  and  $\bar{c}$ . In terms of the nondimensional contact force  $\hat{P}$ , the  $\hat{P}$ – $\bar{c}$  relation takes the form

$$\hat{P} = \bar{c}^2 \left\{ 1 - 3.75B\bar{c}^2 - 6\beta + \frac{228B^2\bar{c}^6}{(1 + 3\beta)} - 3\beta^2 \right\}. \tag{37}$$

The  $\hat{P}$ – $\bar{c}$  relations for various values of  $B$  are plotted in Fig. 7.  $B = 0$  corresponds to the half-plane. It is interesting to note that unlike the simply supported beam, as the contact length increases, the load required for a given contact length is more than that in the half-plane. This is because of the convex shape of the deformed beam. However, the beam curvature effect is not as pronounced as in the case of a simply supported beam (see Fig. 4).

*Contact stresses*

Substituting for  $q_1, \dots, q_4$  in terms of  $q_0$  in eqn (12), the nondimensional contact stresses can be written as

$$\hat{p} = \sqrt{1 - \bar{x}^2} \left[ 1 - \beta(1 - 4\bar{x}^2) - \frac{24B\bar{c}^3\bar{x}}{1 + 3\beta} \right]. \tag{38}$$

The contact stress distribution is unsymmetric about the contact center. A sample contact

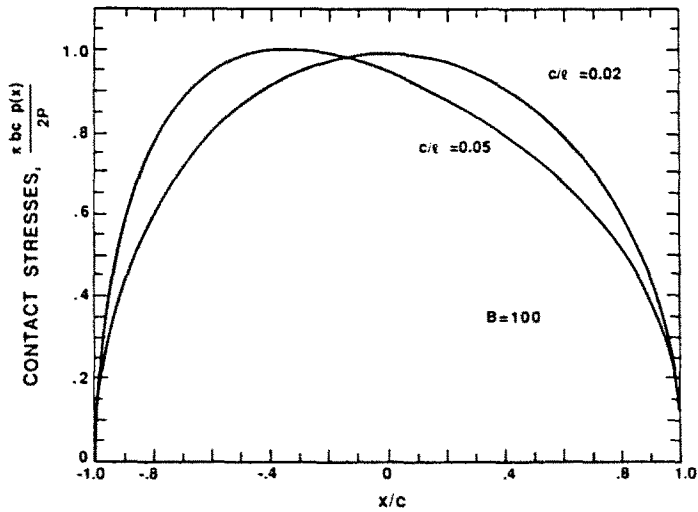

Fig. 8. Contact stresses in cantilever beams.

stress distribution is shown in Fig. 8. In using eqns (37) and (38), care should be taken that the left end of the contact region is not very close to the fixed end of the beam.

*Contact center*

An equation for  $\bar{x}_c$  can be obtained by eliminating  $q_0$  from eqns (31) and (32). This will yield a nonlinear algebraic equation in  $\bar{x}_c$  which can be solved by a simple iterative procedure.  $\bar{x}_c$  will be obtained as a function of  $\bar{c}$ , which in turn can be expressed in terms of  $\hat{P}$  using eqn (37).  $B$  and  $\bar{x}_i$  will be the other parameters in the expression for  $\bar{x}_c$ . The solid lines in Fig. 9 depict the variation of  $\bar{x}_c$  with  $\hat{P}$  for different values of  $B$ . The value of  $\bar{x}_i$  is assumed to be equal to 0.8.

A simple method of determining  $\bar{x}_c$  is described as follows. Assuming that the tangent to the indenter at the contact point will have the same slope as the beam at that point, we obtain the relation

$$\frac{x_1 - x_c}{R} = \frac{6P}{D_1 b h^3} x_c^2,$$

which yields a quadratic equation in  $x_c$ . The solution for  $x_c$  can be expressed in terms of the nondimensional parameters defined earlier :

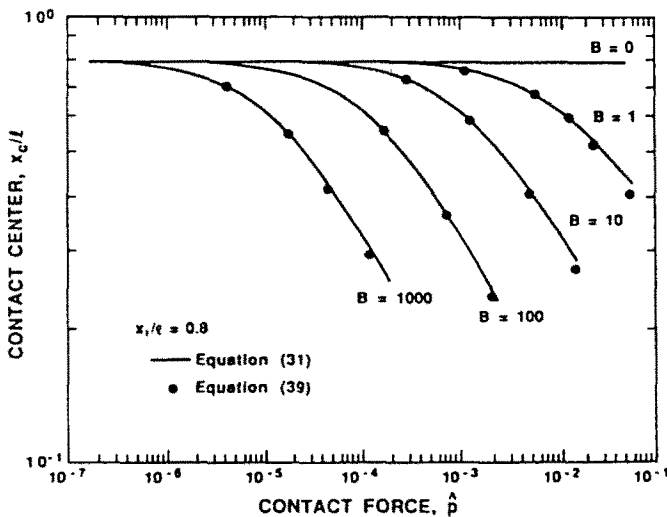

Fig. 9. Location of contact center in cantilever beams.

$$\tilde{x}_c = (-1 + \sqrt{1 + 192\hat{P}B\tilde{x}_c}) / (96\hat{P}B). \quad (39)$$

In Fig. 9, solid circles represent the relation between  $\hat{P}$  and  $\tilde{x}_c$  obtained from eqn (39). It may be seen that eqn (39) provides a simple method of finding  $\tilde{x}_c$  for a given contact force.

#### 4. SUMMARY

The approximate Green's function method described in this paper provides a closed form solution for the problem of contact between a rigid indenter and an orthotropic beam. The dimensionless beam parameter  $B$  and the contact parameter  $\beta$  seem to reflect the effects of beam dimensions, degree of orthotropy of the beam material and contact length to beam length ratio on the contact behavior of the beam. Equations (24) and (25) describe the contact behavior of a simply supported orthotropic beam. In the case of cantilever beams, eqn (39) provides a simple expression for determining the contact center, and eqns (37) and (38) can be used to determine the contact length and the contact stresses. Extension of the present method to other types of beam support is straightforward.

*Acknowledgement*—This work was supported by the National Science Foundation, Solid Mechanics Program, under Grant MSM-8708764.

#### REFERENCES

- Gladwell, G. M. L. (1980). *Contact Problems in the Classical Theory of Elasticity*. Sijthoff and Noordhoff, Alphen aan den Rijn, The Netherlands.
- Keer, L. M. and Ballarini, R. (1983). Smooth contact between a rigid indenter and an initially stressed orthotropic beam, *AIAA J.* **21**, 1035.
- Keer, L. M. and Miller, G. R. (1983). Smooth indentation of a finite layer, *J. Engng Mech. Div. ASCE* **109**, 706.
- Keer, L. M. and Schonberg, W. P. (1986). Smooth indentation of an isotropic cantilever beam, *Int. J. Solids Structures* **22**, 87.
- Lekhnitskii, S. G. (1981). *Theory of Elasticity of an Anisotropic Body*. Mir Publishers, Moscow.
- Sankar, B. V. (1987a). An approximate Green's function for beams and application to contact problems, *ASME J. Appl. Mech.* **54**, 735.
- Sankar, B. V. (1987b). Contact stresses in an orthotropic beam. *Proc. Am. Soc. Composites, 2nd Technical Conf.*, p. 489. Technomic Publishing, Lancaster, Pennsylvania.
- Sankar, B. V. and Sun, C. T. (1983). Indentation of a beam by a rigid cylinder, *Int. J. Solids Structures* **19**, 293.
- Sun, C. T. and Sankar, B. V. (1985). Smooth indentation of an initially stressed orthotropic beam, *Int. J. Solids Structures* **21**, 161.